



* S E - 8 0 7 9 / 3 0 0 *

SE-8079
B. E. - II (Sem. III) (EL/EC/IC)
Examination
May / June - 2011
Circuit & Network

Time : 3 Hours]

[Total Marks : 100

Instructions :

<p>नीचे दर्शाविए निशानीवाणी विगतो उत्तरवही पर अवश्य कभवी. Fillup strictly the details of signs on your answer book.</p> <p>Name of the Examination : B. E. - 2 (SEM. 3) (EL/EC/IC)</p> <p>Name of the Subject : Circuit & Network</p> <p>Subject Code No. : 8 0 7 9 Section No. (1, 2,.....) : NIL</p>	<p>Seat No. :</p> <table border="1" style="width: 100%; height: 20px; border-collapse: collapse;"><tr><td style="width: 15%;"></td><td style="width: 15%;"></td><td style="width: 15%;"></td><td style="width: 15%;"></td><td style="width: 15%;"></td><td style="width: 15%;"></td></tr></table> <div style="border: 1px solid black; border-radius: 15px; height: 60px; margin-top: 10px; display: flex; align-items: center; justify-content: center; padding: 10px;">Student's Signature</div>						

- (2) Attempt all questions.
- (3) Figure to the right indicate full marks.
- (4) Assume suitable data wherever required.
- (5) Scientific calculator upto casio-super fx 100 D 100 W, 100 MS series and equivalent are permitted.

- 1 (a) Discuss the following : 10
- (i) Linear and Non-linear Network
 - (ii) Bilateral and Unilateral Network
 - (iii) Active and Pasive Network
 - (iv) Mesh and Node
 - (v) Independent and Dependent sources.
- (b) Explain procedure to obtain dual of the network. 5
- (c) Find current through 5Ω resistor using Node Voltage Analysis. 5

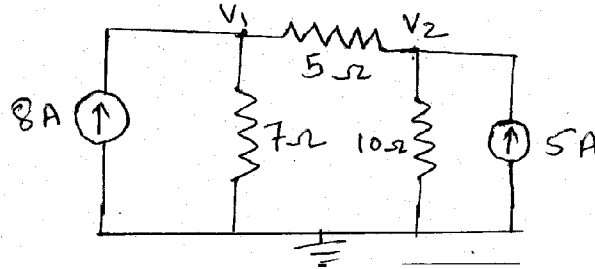

Fig. 1

2 Attempt any two :

15

- (i) Determine current through 4Ω resistor using mesh current analysis.

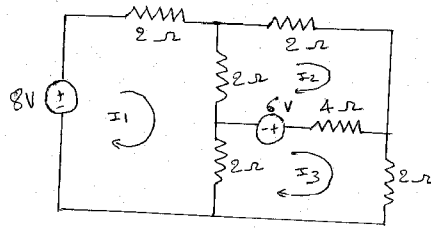

Fig. 2

- (ii) Explain following terms :

(a) Graph (b) Oriented graph (c) Tree (d) Co-tree

- (iii) Obtain current I_x using Thevenin's Theorem.

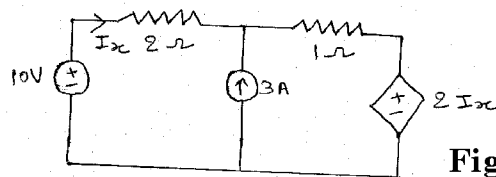

Fig. 3

- (iv) Find voltage V_B using Nodal Analysis.

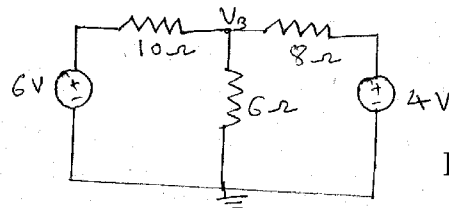

Fig. 4

- 3 (a) Determine current I through R_3 in network shown using super position theorem.

8

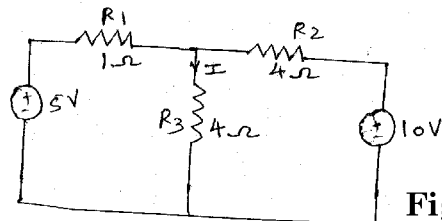

Fig. 5

- (b) For the network shown below draw graph and oriented graph

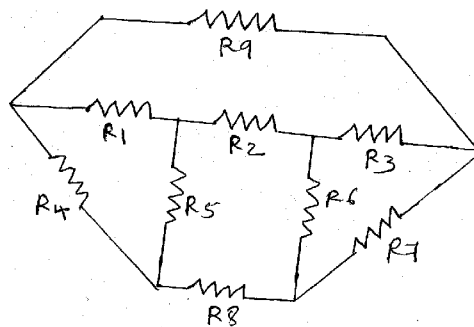

Fig. 6

OR

- 3 (a) Using Norton's theorem find current through terminal ab in network. 8

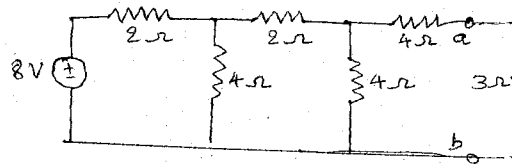

Fig. 7

- (b) In the network shown, the resistor R absorbs maximum power. Calculate the value of R and maximum power transfer.

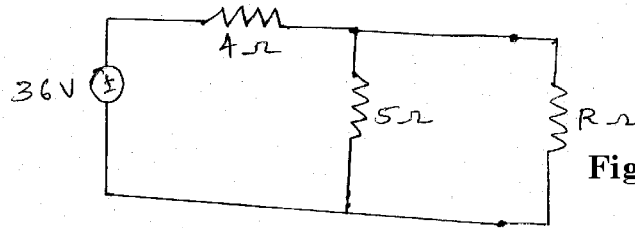

Fig. 8

- 4 (a) Do as directed : 10
- What are condition for symmetry and reciprocity for Z parameters? 2
 - What is unit of A and C in ABCD parameters ? 2
 - Define poles and zeroes of transfer function. 2
 - Define time constant of R L series circuit. 2
 - Match the following : 2

	f(t)	F(s)
(i)	$\delta(t)$	$1/s$
(ii)	t	$1/s^2$
(iii)	t^2	$2/s^3$
(iv)	$u(t)$	1

- (b) What is significant of initial condition ? Write a note on initial condition in basic circuit element. 4
- (c) States convolution theorem. Find the laplace inverse of $\frac{K}{S(S+1)}$ using convolution theorem. 6
- 5 (a) Find time response R-L series circuit for impulse input. 6
- (b) Find initial value and final value $i(t)$ using Thevenin theorem as well as by standards Laplace inverse method of figure 9. Assume initial conditions are zero. 9

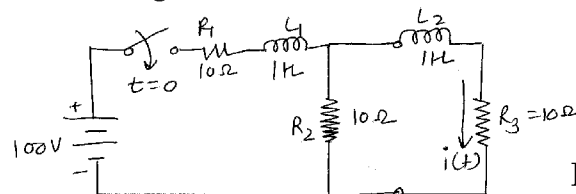

Fig. 9

OR

- 5 (a) Find time response of R-C series circuit for step input. 7
- (b) State and prove final and initial value theorems and find initial and final value of following functions : 8
- $f(t) = 2e^{-3t}$
 - $2 - e^{3t}$

6 Attempt any three :

15

- (i) The network shown in figure 10 is in steady state with switch K closed. At $t=0$, the switch is opened. Determine the voltage across the switch V_k and dV_k/dt at $t=0^+$.
- (ii) Write down advantages of s domain network.

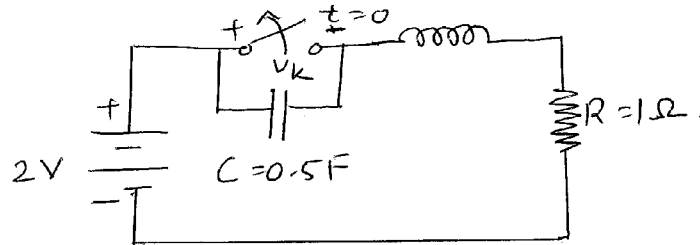

Fig. 10

- (iii) Find the impedance of the network in s domain across the terminals of figure 11.

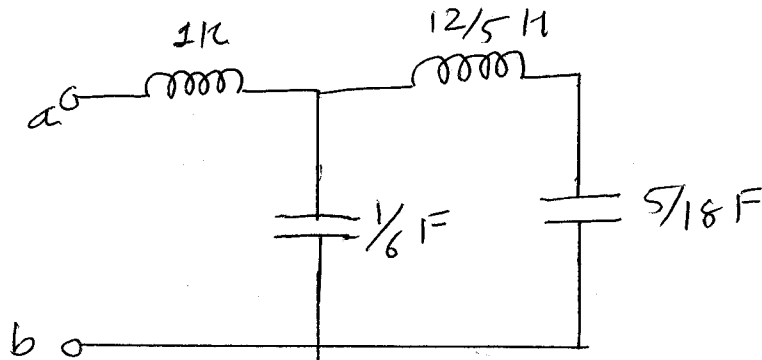

Fig. 11

- (iv) Derive Z parameters in terms of ABCD parameters.
- (v) Find Z parameters for the network shown in following figure 12.

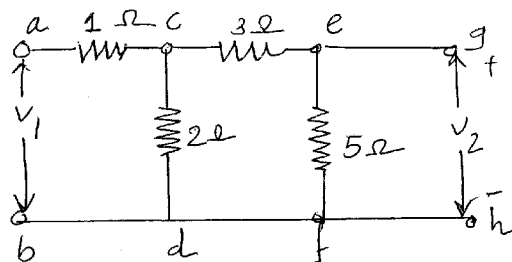

Fig. 12